



Aviation Investigation Final Report

Location:	Myrtle Beach, South Carolina	Accident Number:	ERA21FA224
Date & Time:	May 21, 2021, 18:14 Local	Registration:	N575BC
Aircraft:	Piper PA-31P	Aircraft Damage:	Destroyed
Defining Event:	Aircraft maintenance event	Injuries:	1 Fatal
Flight Conducted Under:	Part 91: General aviation - Personal		

Analysis

The accident flight was the first flight after an annual inspection during which all flight control surfaces were removed, repainted, and reinstalled. After departure, the pilot reported that he needed to return to the runway. The airplane’s altitude fluctuated between 1,000 ft and 450 ft mean sea level before radar contact was lost. Examination of the engines and propellers revealed no mechanical failures or anomalies that would have precluded normal operation. Examination of the airframe revealed that the elevator trim tabs were installed upside-down and reversed, which would have resulted in the tabs moving opposite of the intended direction. A command from the cockpit controls for nose-up trim would result in the tabs moving in the airplane nose-down direction and vice versa. As found, both trim tabs were deflected trailing edge up, which corresponded to a nose-down trim setting.

The mechanic who approved the airplane to be returned to service stated that, after the control surfaces were reinstalled, he examined the primary flight controls for proper movement but did not verify proper movement of the elevator trim tab. Although the control surfaces were tagged with labels as they were removed, those labels likely did not remain attached throughout the painting process, which contributed to their improper reinstallation.

The maintenance facility also maintained a different version of the accident airplane, which was designed with the elevator trim tab control rod and control horn positioned on the bottom of the trim tab. It is possible that the mechanic may have thought the trim tab installation on the accident airplane was the same, which could explain why the mechanic inadvertently installed the elevator trim tabs in reverse. Although the illustrated parts catalog (IPC) warned in the introduction section that the IPC should not be used for rigging and installation purposes, a figure on a subsequent page of the IPC incorrectly depicted the elevator trim tab control horn positioned on the bottom side of the elevator trim tab. Had the mechanic referred to this figure, it may have contributed to the incorrect installation of the trim tabs.

It is likely that the pilot applied nose-up trim during takeoff, and subsequently experienced nose-down trim forces due to the improper installation of the trim tab. After 2 minutes of flight, the pilot was unable to maintain control of the airplane, possibly due to the unexpected control forces, which resulted in a rapid descent and collision with terrain.

Toxicology testing detected ethanol in the pilot's liver (0.225 and 0.078 gm/hg) and muscle tissue (0.144 gm/hg). Another postmortem microbial product, propanol, was detected in his liver tissue by one laboratory and in muscle tissue by a second laboratory. When consumed, ethanol distributes quickly and uniformly to body tissues based on water content. One would expect the concentrations in the two liver tissue samples to be similar and the concentrations in liver and muscle tissue to be similar as well. Given the different ethanol tissue concentrations, the state in which the body was recovered, and the presence of n-propanol in liver and muscle tissue, it is likely that the identified ethanol was from sources other than ingestion. Thus, the identified ethanol did not contribute to this accident.

Probable Cause and Findings

The National Transportation Safety Board determines the probable cause(s) of this accident to be:

The mechanic's inadvertent installation of the elevator trim tabs in reverse, which resulted in the pitch trim system operating opposite of the pilot's input and the pilot's subsequent loss of control.

Findings

Aircraft	Elevator tab control system - Incorrect service/maintenance
Personnel issues	Repair - Maintenance personnel
Personnel issues	Aircraft control - Pilot

Factual Information

History of Flight

Approach-VFR pattern downwind	Sys/Comp malf/fail (non-power)
Prior to flight	Aircraft maintenance event (Defining event)

On May 21, 2021, at 1814 eastern daylight time, a Piper PA-31P, N575BC, was destroyed when it was involved in an accident near Myrtle Beach, South Carolina. The airline transport pilot was fatally injured. The airplane was operated as a Title 14 *Code of Federal Regulations* Part 91 personal flight.

The accident flight was the airplane's first flight following completion of an annual inspection. Before the flight, the airplane was fueled with 167.5 gallons of 100 low lead aviation fuel.

The airplane departed Myrtle Beach International Airport (MYR), Myrtle Beach, South Carolina, at 1812, with the intended destination of Grand Strand Airport (CRE), North Myrtle Beach, South Carolina. According to automatic dependent surveillance-broadcast and air traffic control (ATC) communications information, the pilot established contact with ATC and reported that he was ready for departure from runway 18. He was instructed to fly runway heading, climb to 1,700 ft mean sea level (msl), and was cleared for takeoff. Once airborne, the controller instructed the pilot to turn left; however, the pilot stated that he needed to return to runway 18. The controller instructed the pilot to enter a right closed traffic pattern at 1,500 ft msl.

As the airplane continued to turn to the downwind leg of the traffic pattern, it reached an altitude of about 1,000 ft mean sea level (msl). While on the downwind leg of the traffic pattern, the airplane descended to 450 ft msl, climbed to 700 ft msl, and then again descended to 475 ft msl before radar contact was lost. About 1 minute after the pilot requested to return to the runway, the controller asked if any assistance was required, to which the pilot replied, "yes, we're in trouble." There were no further radio communications from the pilot.

Pilot Information

Certificate:	Airline transport; Commercial; Flight instructor	Age:	60, Male
Airplane Rating(s):	Single-engine land; Single-engine sea	Seat Occupied:	Left
Other Aircraft Rating(s):	None	Restraint Used:	Unknown
Instrument Rating(s):	Airplane	Second Pilot Present:	No
Instructor Rating(s):	Airplane multi-engine; Airplane single-engine	Toxicology Performed:	Yes
Medical Certification:	Class 1 With waivers/limitations	Last FAA Medical Exam:	December 23, 2020
Occupational Pilot:	Yes	Last Flight Review or Equivalent:	
Flight Time:	20000 hours (Total, all aircraft)		

Aircraft and Owner/Operator Information

Aircraft Make:	Piper	Registration:	N575BC
Model/Series:	PA-31P	Aircraft Category:	Airplane
Year of Manufacture:	1977	Amateur Built:	
Airworthiness Certificate:	Normal	Serial Number:	31P-7730004
Landing Gear Type:	Retractable - Tricycle	Seats:	8
Date/Type of Last Inspection:	May 19, 2021 Annual	Certified Max Gross Wt.:	
Time Since Last Inspection:		Engines:	2 Reciprocating
Airframe Total Time:	4826.6 Hrs as of last inspection	Engine Manufacturer:	Lycoming
ELT:	Installed, activated, did not aid in locating accident	Engine Model/Series:	TIGO-541-E1A
Registered Owner:		Rated Power:	425 Horsepower
Operator:	On file	Operating Certificate(s) Held:	None

The airplane's most recent annual inspection was completed on May 19, 2021. Maintenance performed at that time included removing, repainting, and reinstalling the primary and secondary flight control surfaces.

Meteorological Information and Flight Plan

Conditions at Accident Site:	Visual (VMC)	Condition of Light:	Day
Observation Facility, Elevation:	MYR,25 ft msl	Distance from Accident Site:	2 Nautical Miles
Observation Time:	17:56 Local	Direction from Accident Site:	91°
Lowest Cloud Condition:	Clear	Visibility	10 miles
Lowest Ceiling:	None	Visibility (RVR):	
Wind Speed/Gusts:	10 knots /	Turbulence Type Forecast/Actual:	/
Wind Direction:	110°	Turbulence Severity Forecast/Actual:	/
Altimeter Setting:	30.4 inches Hg	Temperature/Dew Point:	24°C / 18°C
Precipitation and Obscuration:	No Obscuration; No Precipitation		
Departure Point:	Myrtle Beach, SC (MYR)	Type of Flight Plan Filed:	
Destination:	North Myrtle Beach, SC (CRE)	Type of Clearance:	Unknown
Departure Time:	18:12 Local	Type of Airspace:	Class C

Airport Information

Airport:	MYRTLE BEACH INTL MYR	Runway Surface Type:	Asphalt
Airport Elevation:	25 ft msl	Runway Surface Condition:	Dry
Runway Used:	18/36	IFR Approach:	None
Runway Length/Width:	9503 ft / 150 ft	VFR Approach/Landing:	None

Wreckage and Impact Information

Crew Injuries:	1 Fatal	Aircraft Damage:	Destroyed
Passenger Injuries:	N/A	Aircraft Fire:	On-ground
Ground Injuries:	N/A	Aircraft Explosion:	None
Total Injuries:	1 Fatal	Latitude, Longitude:	33.685597,-78.968609

The airplane impacted in a field about 0.1 mile from the last radar return, at an elevation of 20 ft. A postimpact fire ensued, and the debris field was about 400 ft long by 150 ft wide. All major components of the airplane were in the vicinity of the main wreckage. Each engine came to rest in about a 5-ft crater and remained attached to the fuselage.

The left engine crankcase was impact damaged in multiple locations. The gearbox was impact separated. All valve covers remained intact and attached to the cylinders. The valve covers were removed, and no anomalies were noted. Examination with a lighted borescope revealed crankshaft and camshaft continuity and no anomalies of the cylinders. All engine accessories were impact separated and fragmented. The left engine turbocharger was impact separated and would bind when rotated by hand; scoring was noted on the casing.

The right engine crankcase was impact damaged in multiple locations. All valve covers remained intact and attached to the cylinders. The valve covers were removed and no anomalies were noted. Examination with a lighted borescope revealed crankshaft and camshaft continuity and no anomalies of the cylinders. All engine accessories were impact separated and fragmented. The oil suction screen was removed and was not occluded. The right engine turbocharger was impact separated and would bind when rotated by hand.

The left propeller was impact separated from the engine. Two of the three blades were separated from the hub. All blades exhibited polishing. One blade was bent forward, one exhibited tip curling, and the last blade was bent aft. The blade that was bent aft remained attached to the propeller hub.

The right propeller was impact separated from the right engine. Two of the three blades were impact separated from the hub. All blades exhibited polishing. One blade was bent forward, one blade was bent aft, and one blade remained straight. The straight blade remained attached to the propeller hub.

Flight control cable continuity was established from all flight control surfaces to the cockpit through multiple overload breaks in the cables. The wings and fuselage were largely consumed by fire. The remaining skin and structure exhibited accordion-like impact damage that was symmetrical on both wings. The landing gear was in the extended position. The flaps were in the retracted position. The empennage was separated from the fuselage and located about 50 ft from the main wreckage. The top section of the vertical stabilizer and the rudder were impact-crushed downward. The elevator remained attached to the right horizontal stabilizer. The right trim tab remained attached to the right elevator, was deflected trailing edge up, but was impact separated from the control rod. The left trim tab remained attached to the left elevator, the connecting rod remained attached to the flight controls, and it was deflected trailing edge up.

Further examination of the elevator trim tabs revealed that both were installed upside-down and reversed (the left tab was installed on the right elevator and the right tab on the left elevator). As a result, the control horns on both trim tabs and their respective control rods, which should have been located on the top side of the trim tabs above the tab's hinge line, were instead located on the bottom side of the tabs below the tab's hinge line. This installation resulted in a reversal of the direction of the trim tabs' movements; a command of nose-up trim from the cockpit controls would incorrectly move the trim tabs in the nose-down direction, and vice versa.

Additional Information

Maintenance Facility

According to the director of maintenance, during the annual inspection, corrosion was noted on the flight control surfaces, and the surfaces were removed from the airplane for corrosion removal, repair, and repainting. When the primary and secondary flight control surfaces were removed, they were tagged; however, during the process of repainting, because of the corrosive solutions the tag was separated from the control surface.

After the maintenance was performed on the airplane, the director of maintenance had another mechanic sit in the airplane and exercise the controls while he verified the primary flight control movement to ensure that they were installed properly. He did not check the elevator trim tab movement for proper installation. The director of maintenance, who was a mechanic with inspection authorization, approved the airplane for return to service.

The director of maintenance further stated that he also maintained a non-pressurized Piper PA-31 (the accident airplane was the pressurized version). The non-pressurized PA-31 was equipped with only one elevator trim tab located on the right side of the elevator, and the control horn and control rod were located on the bottom side of the trim tab.

PA-31P Illustrated Parts Catalog

According to the Piper PA-31P illustrated parts catalog, the Elevator Assembly figure incorrectly depicted the control horn on the bottom of the trim tab. (see Figure 1.) The illustrated parts catalog also noted in the Introduction section that, “UNDER NO CIRCUMSTANCES SHALL THIS CATALOG BE USED FOR RIGGING AND INSTALLATION PURPOSES.”

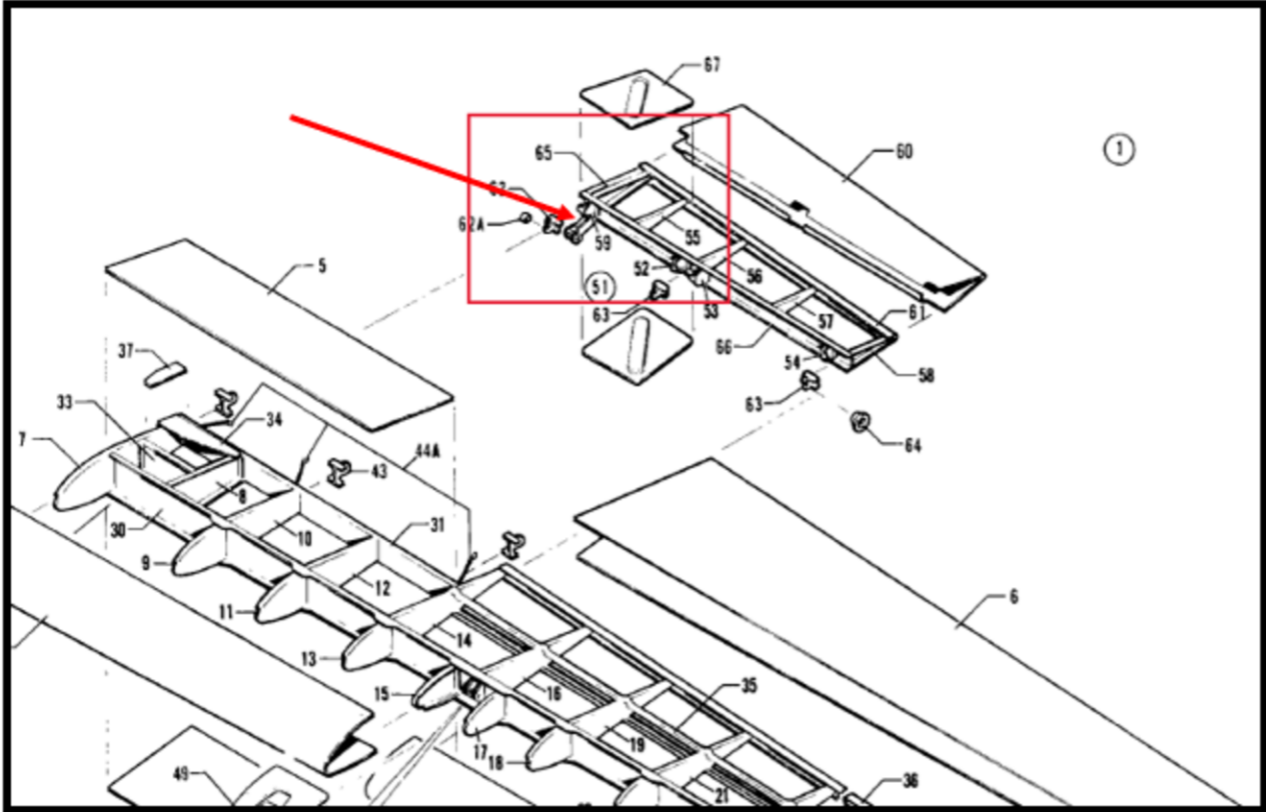

Figure 1. Excerpt from Illustrated Parts Catalog showing the control horn located on the bottom side of the elevator trim tab.

PA-31P Maintenance Manual

According to the Piper PA-31P maintenance manual, the elevator and elevator trim control figures correctly depicted that the control rod attached to the control horn as located on the top of the elevator trim tab. The instructions to install the elevator trim tab indicated to, “refer to figure 4-5.” Figure 2 is an excerpt from Figure 4-5 in the maintenance manual.

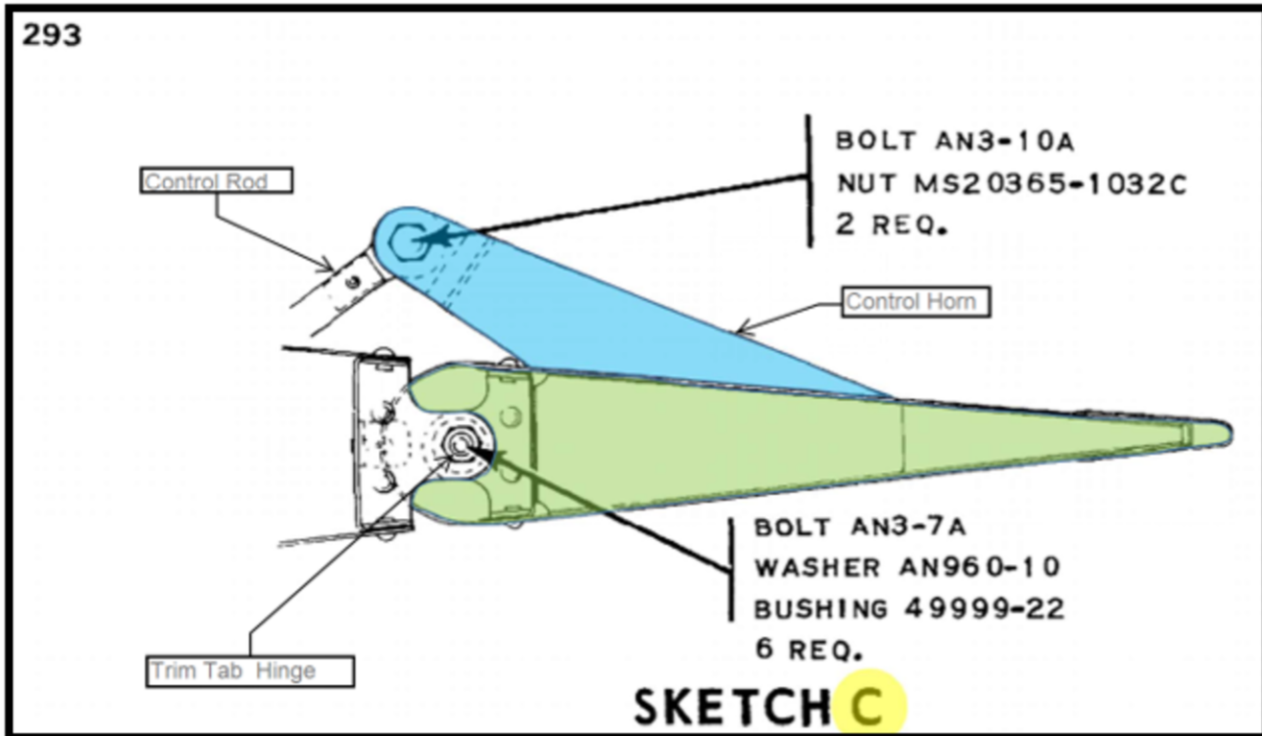

Figure 2. Excerpt from Airplane Maintenance Manual showing the trim tab hinge, with the control horn, and control rod located on the top side of the elevator trim tab.

Medical and Pathological Information

Toxicology testing performed for the Department of Pathology and Laboratory Medicine's office detected ethanol at 0.225 milligrams per hectogram (mg/hg) and isopropanol in the pilot's liver tissue. Caffeine was also detected in his liver tissue. Toxicology testing performed by the FAA Forensic Sciences Laboratory detected ethanol in the pilot's liver tissue at 0.078 gm/hg and in his muscle tissue at 0.144 gm/hg; n-propanol was detected in muscle tissue. The non-sedating fever and pain medication acetaminophen was detected in his liver and muscle tissue.

Ethanol is a social drug commonly consumed by drinking beer, wine, or liquor. It acts as a central nervous system depressant; it impairs judgment, psychomotor functioning, and vigilance. Ethanol is water soluble, and after absorption it quickly and uniformly distributes throughout the body's tissues and fluids. The distribution pattern parallels water content and blood supply of the tissue. Ethanol can be produced after death by microbial activity;

sometimes in conjunction with other alcohols, such as propanol. Extensive trauma increases the spread of bacteria and raises the risk of ethanol production after death.

Administrative Information

Investigator In Charge (IIC):	Kemner, Heidi		
Additional Participating Persons:	James Jackson; FAA/FSDO; Columbia, SC Damian Galbraith; Piper Aircraft; Vero Beach, FL Troy Helgeson; Lycoming Engines; Williamsport, PA		
Original Publish Date:	August 12, 2022	Investigation Class:	3
Note:			
Investigation Docket:	https://data.nts.gov/Docket?ProjectID=103126		

The National Transportation Safety Board (NTSB), established in 1967, is an independent federal agency mandated by Congress through the Independent Safety Board Act of 1974 to investigate transportation accidents, determine the probable causes of the accidents, issue safety recommendations, study transportation safety issues, and evaluate the safety effectiveness of government agencies involved in transportation. The NTSB makes public its actions and decisions through accident reports, safety studies, special investigation reports, safety recommendations, and statistical reviews.

The Independent Safety Board Act, as codified at 49 U.S.C. Section 1154(b), precludes the admission into evidence or use of any part of an NTSB report related to an incident or accident in a civil action for damages resulting from a matter mentioned in the report. A factual report that may be admissible under 49 U.S.C. § 1154(b) is available [here](#).